

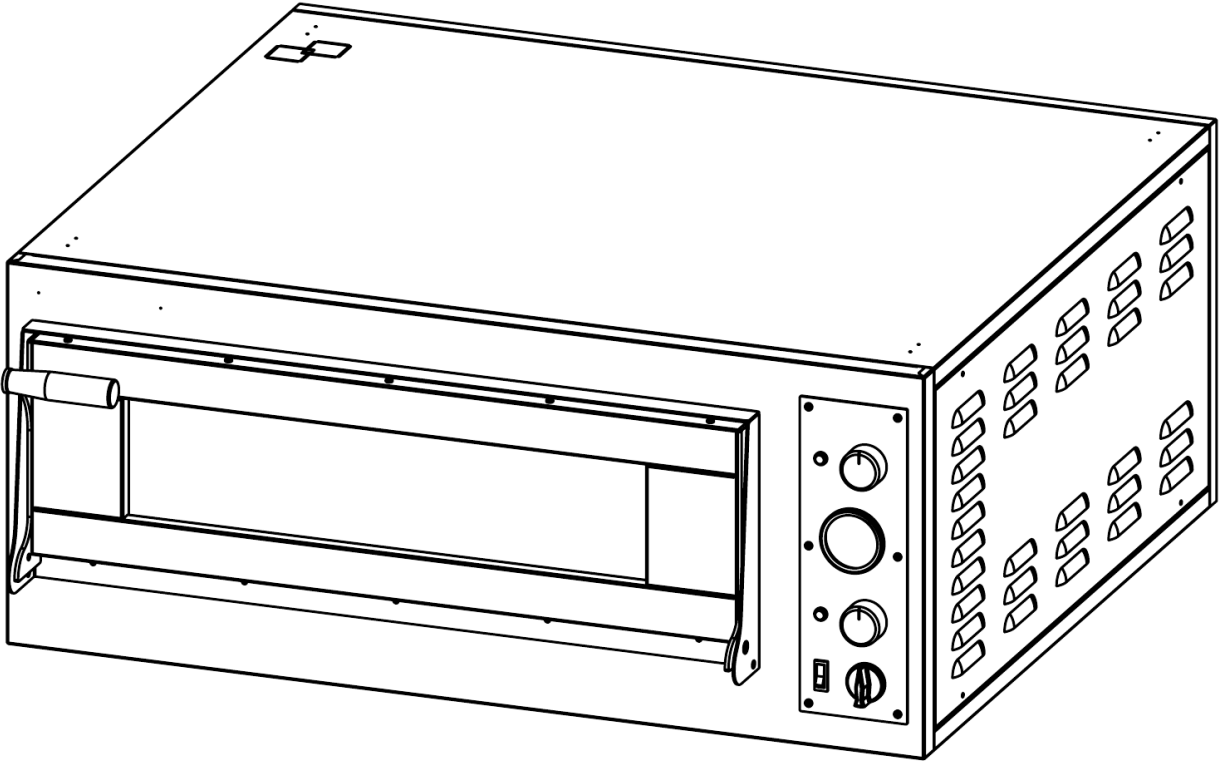

INSTRUCTIONS FOR USE AND MAINTENANCE

**ELECTRIC OVENS FOR PIZZA
MILAN - ROME - NAPELS**



ENGLISH



WARNING!

BEFORE SWITCHING ON THE OVEN: REMOVE THE REFRACTORY STONES CAREFULLY, REMOVE THE POLYSTYRENE UNDER ALL THE STONES, AND THEN PUT AGAIN THE STONES INSIDE THE ROOM OF THE OVEN.

ВНИМАНИЕ!

ПЕРЕД ПЕРВЫМ ВКЛЮЧЕНИЕМ ПЕЧИ ОСТОРОЖНО ПРИПОДНЯТЬ ШАМОТНЫЙ КАМЕНЬ И ДОСТАТЬ ПОЛИСТИРОЛОВЫЙ УПЛОТНИТЕЛЬ ПОД КАМНЯМИ. АККУРАТНО ПОЛОЖИТЬ КАМЕНЬ В ПЕРВОНАЧАЛЬНОЕ ПОЛОЖЕНИЕ.

ATTENTION!

AVANT D'ALLUMER LE FOUR, ENLEVER LES PIERRE SOIGNEUSEMENT, ENLEVER LE POLYSTYRENE QUI SE TROUVE DESSOUS TOUTES LES PIERRES ET, SEULEMENT APRES AVOIR FAIT CA, REMETTRE LES PIERRE DANS LE FOUR.

ATTENZIONE!

PRIMA DI METTERE IN FUNZIONE IL FORNO SOLLEVARE CON CAUTELA LE PIETRE, TOGLIERE IL POLISTIROLO DA SOTTO TUTTE LE PIETRE PRESENTI, MANEGGIARE LE PIETRE CON CURA E DOPO AVER RIMOSSO IL POLISTIROLO RIMETTERE LE PIETRE ALL'INTERNO DELLA CAMERA.

ATENDIMENTO!

ANTES DE PÔR EM FUNCIONAMEINTO O FORNO , LEVANTAR COM CUIDADO AS PEDRAS , TIRAR O POLIESTIRENO PRESENTE EMBAIXO DAS PEDRAS, MANIPULAR COM CUIDADO AS PEDRAS E DEPOIS DE TER TIRADO O POLIETIRENO VOLTAR A COLOCAR AS PEDRAS DENTRO DA CÂMARA.

¡ATENCIÓN!

ANTES DE PONER EN MARCHA EL HORNO, LEVANTAR CON CUIDADO LAS PIEDRAS, QUITAR EL POLIESTERENO QUE SE ENCUENTRA DEBAJO DE ESTAS, MANIPULAR LAS PIEDRAS CON CUIDADO Y TRAS HABER QUITADO EL POLIESTERENO VOLVER A RECOLOCARLAS EN EL INTERIOR DE LA CÁMARA.

ACHTUNG!

UNTER DEN STEINEN BEFINDET SICH EINE SCHICHT AUS POLYSTYROL, BITTE DIESES POLYSTYROL VOR DEM EINSCHALTEN DES OFENS ENTFERNEN. BEHANDLE DIE STEINE SORGFÄLTIG UND, NACH DEM ENTFERNEN DES POLYSTYROLS, LEGEN SIE DIE STEINE WIEDER IN DEN KAMMERN

UWAGA!

PRZED URUCHOMIENIEM PIECA NALEŻY W PIERWSZEJ KOLEJNOŚCI WYJĄĆ Z PIECA PŁYTY SZAMOTOWE, USUNĄĆ ZABEZPIECZENIE STYROPIANOWE, A NASTĘPNIE PONOWNIE UMIEŚCIĆ PŁYTY SZAMOTOWE W PIECU.

تنبيه:

قبل استخدام الفرن ارفع الأحجار بحذر، وأزل البوليستيرين من تحت جميع الأحجار الموجودة، تعامل مع الأحجار بحذر، وبعد إزالة البوليستيرين أعد وضع الأحجار داخل الغرفة.

INDEX

MARKING PLATE	4
SERIAL LABEL	4
GENERAL INFORMATION	4
THE IMPORTANCE OF THE MANUAL	4
STATUS OF "TURNED OFF OVEN"	4
WARRANTY	4
TECHNICAL DESCRIPTIONS	5
TECHNICAL DATA	5
DESTINATION OF USE.....	8
LIMITS OF USE.....	8
INSTALLATION	8
INSTRUCTIONS FOR THE USER	8
ELECTRIC CONNECTION	9
TERMINAL BOX	10
EQUIPOTENTIAL	10
USE AND FUNCTIONING	11
CONTROL PANEL	11
FIRST COMMISIONING.....	12
TURNING ON OVEN	12
TURNING OFF OVEN	13
MAINTENANCE	13
CLEANING	13
DEMOLITION	13
GENERAL WARNINGS.....	13
SPARE PARTS	14
EXPLODED VIEW	14
SPARE PARTS.....	29
ELECTRIC EQUIPMENT	22
WIRING DIAGRAMS	23

MARKING PLATE

SERIAL LABEL

The plate bears in readable and indelible way the following data:

- Name of the manufacturer;
- CE marking;
- Model (MOD);
- Electric power (kW/A);
- "Made in Italy"
- Serial number ;
- Electric voltage and frequency (Volt/Hz);
- Year of construction ;
- Weight of the oven;

GENERAL INFORMATION

THE IMPORTANCE OF THE MANUAL

Before using the concerned oven, it is compulsory to read and understand this manual in all its parts.

This manual must always be available for the "authorized operators" and has to be placed and preserved close to the oven.

The manufacturer declines all liability for eventual damages to persons, animals, and things caused by the inobservance of the regulations described in this manual.

This manual is an integral part of the oven and must be preserved until its final dismantling.

The "authorized operators" must perform on the oven exclusively interventions for which they are specifically competent.

STATUS OF "TURNED OFF OVEN"

Before performing any type of maintenance and/or adjustment intervention, it is compulsory to disconnect the power supply source, disconnecting the power supply plug from the mains outlet verifying that the oven is effectively turned off and cooled.

WARRANTY

The manufacturer warrants that the concerned ovens are tested at manufacturer's premises. The warranty of the oven is of **12 (twelve) months**.



THE TAMPERING AND/OR REPLACEMENT OF PARTS WITH NON ORIGINAL SPARE PARTS CAUSE THE DECAY OF THE WARRANTY AND RELEASE THE MANUFACTURER FROM ANY LIABILITY.

TECHNICAL DESCRIPTIONS

TECHNICAL DATA

	Measur ement unit	MILAN 1	MILAN 2	ROME 1	ROME 2	NAPELS 1	NAPELS 2
Temperature control	°C	45-455					
External dimensions	cm	L 130,5 P 60,0 H 41,3	L 130,5 P 60,0 H 74,5	L 100,0 P 95,5 H 41,3	L 100,0 P 95,5 H 74,5	L 136,0 P 95,5 H 41,3	L 136,0 P 95,5 H 74,5
Chamber dimensions		L 108,0 P 41,0 H 14,0	L 108,0 P 41,0 H 14,0	L 72,0 P 72,0 H 14,0	L 72,0 P 72,0 H 14,0	L 108,0 P 72,0 H 14,0	L 108,0 P 72,0 H 14,0
Chambers	nr	1	2	1	2	1	2
Voltage	Vac	400/230					
Frequency	Hz	50/60					
Total power	kW	6,0	12,0	6,0	12,0	9,0	18,0
Power of top heating element	W	3000x1	3000x2	3000x1	3000x2	1500x3	1500x6
Power of bottom heating element	W	3000x1	3000x2	3000x1	3000x2	1500x3	1500x6

DESTINATION OF USE

The foreseen use for which this oven has been designed and produced is the following:



FORESEEN USE: PIZZA BAKING, GRATINATING OF GASTRONOMY PRODUCTS AND HEATING OF FOODSTUFF IN BAKING PANS.



THE OVEN CAN BE USED EXCLUSIVELY BY AN AUTHORIZED OPERATOR (USER).



THIS APPLIANCE IS NOT INTENDED FOR USE BY PERSONS (INCLUDING CHILDREN) WITH REDUCED PHYSICAL, SENSORY OR MENTAL CAPABILITIES, OR LACK OF EXPERIENCE AND KNOWLEDGE, UNLESS THEY HAVE BEEN GIVEN SUPERVISION OR INSTRUCTION CONCERNING USE OF THE APPLIANCE BY A PERSON RESPONSIBLE FOR THEIR SAFETY.



CHILDREN SHOULD BE SUPERVISED TO ENSURE THAT THEY DO NOT PLAY WITH THE APPLIANCE

LIMITS OF USE

This oven has been designed and manufactured exclusively for the destination of use described above, therefore, any other type of use is strictly forbidden in order to assure, at any time, the safety of the authorized operators, as well as the efficiency of the oven itself.

INSTALLATION

INSTRUCTIONS FOR THE USER

The place where the oven is installed must have the following environmental characteristics:

- To be dry;
- Water sources at safe distance;
- Adequate ventilation and lighting corresponding to hygiene and security rules following the existing laws.



THE OVEN MUST NOT BE INSTALLED IN PROXIMITY OF THE INFLAMMABLE MATERIALS (WOODS, PLASTIC, COMBUSTIBLE, GAS, ETC.). AVOID THE CONTACT OF INFLAMMABLE OBJECTS WITH THE HOT SURFACES OF THE OVEN. ALWAYS ASSURE THE SAFETY FIREPROOF CONDITIONS. MAINTAIN A FREE SPACE AROUND THE OVEN OF AT LEAST 30 CM.

Verify that the electrical set-up corresponds with the numbers of the technical characteristics on the small plate at the back of the oven. The characteristics of the electric socket must be compatible with the plug installed on the cable.

ELECTRIC CONNECTION



THE ELECTRIC CONNECTION OF THE OVEN TO THE MAINS MUST BE COMPULSORILY AND EXCLUSIVELY PERFORMED BY AN AUTHORIZED TECHNICIAN (ELECTRICIAN) SATISFYING THE TECHNICAL AND PROFESSIONAL REQUIREMENTS STATED BY THE REGULATIONS IN FORCE IN THE COUNTRY OF USE OF THE OVEN, WHO MUST ISSUE A DECLARATION OF CONFORMITY FOR THE INTERVENTION PERFORMED.



FOR DIRECT CONNECTION TO THE NETWORK, YOU MUST HAVE A DEVICE THAT HAS A CONTACT GAP TO ENSURE THE COMPLETE DISCONNECTION, IN THE CONDITIONS OF OVERVOLTAGE CATEGORY III, IN ACCORDANCE WITH THE RULES FOR INSTALLATION.

To connect the machine to the electric network it is necessary to proceed as follows:

- 1) connect to the wires to the terminals L1—L2—L3—N — \perp of power cord type H07RNF 3G X "x" mm² unsheathed with ferule;
- 2) put together the other end of the cable and a plug, which is normalised and polarised (the distinction between phase and neutral must be unequivocal).
- 3) to connect the oven to 230 V single phase is sufficient to make a bridge between L1-L2-L3 with the special plates present in the terminal box

L1	Clamp N.1
L2	Clamp N.2
L3	Clamp N. 3
N	Clamp N. 4 or N. 5
\perp	Clamp N. 6



ONCE THE ELECTRIC CONNECTION HAS BEEN PERFORMED, THE AUTHORIZED TECHNICIAN (ELECTRICIAN) MUST ISSUE A DECLARATION CERTIFYING THE MEASUREMENT OF THE CONTINUITY OF THE EQUIPOTENTIAL PROTECTION CIRCUIT.



THE APPLIANCE IS TO BE SUPPLIED THROUGH A RESIBASIC CURRENT DEVICE (RCD) HAVING A RATED RESIBASIC OPERATING CURRENT NOT EXCEEDING 30 MA

TERMINAL BOX

The terminal box is placed externally on the back of the oven.

400 V
3 PH

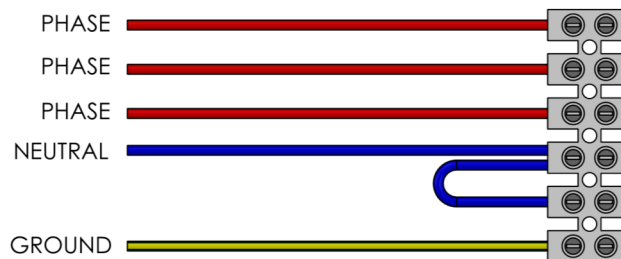

230 V
1 PH

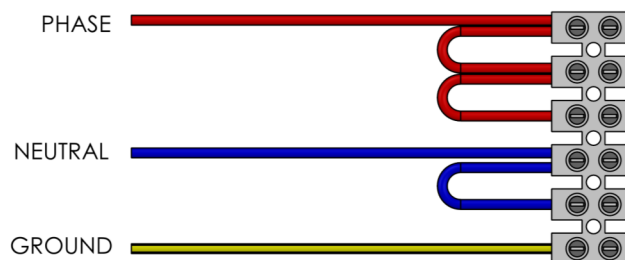

230 V
3 PH



Oven type	N. of cables	Section (mm ²)
Single phase, one chamber	3	4
Single phase, two chambers and versions 9 single phase	3	6
Three phase one chamber and two chambers	5	4
Three phase from versions 9 and up	5	6

EQUIPOTENTIAL

The equipment must be connected with an equi-potential system . the connection terminal is located near the terminal box. The bonding wire must have a minimal section of 10 mm².

USE AND FUNCTIONING

CONTROL PANEL

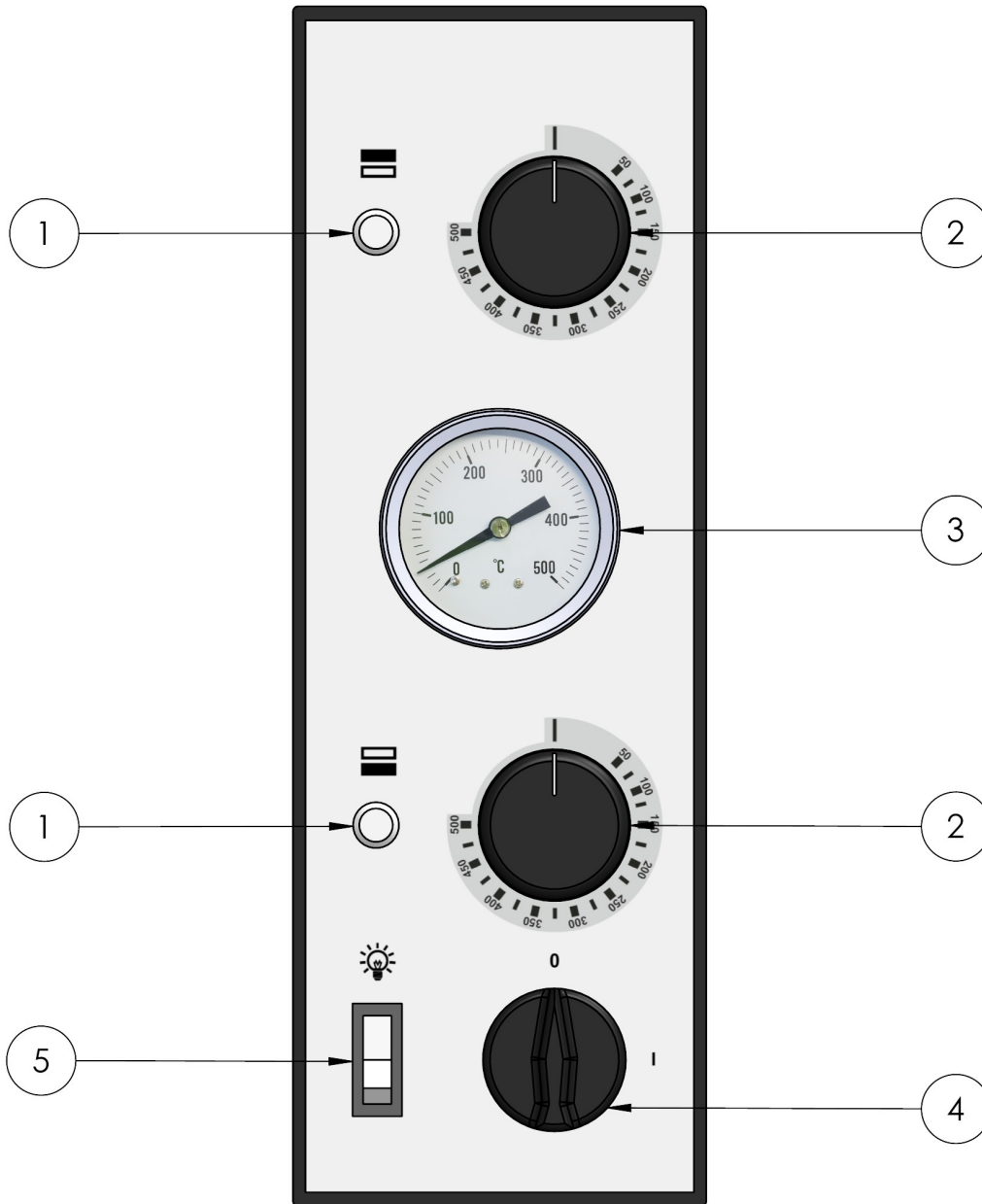

REF.	DENOMINATION	FUNCTION
1	Warning light	If lighted, it signals the operation of the resistor in use.
2	Thermostat	<ul style="list-style-type: none"> • Pos.0:it disables the operation of the resistor; • Pos. 0-500°C :it enables the operation of the resistor and sets the wished temperature.
3	Thermometer	Indicates the temperature in the baking chamber.
4	Switch heating element	<ul style="list-style-type: none"> • Pos. I: It enables the operation of the resistor; • Pos. 0: It disables the operation of the resistor.
5	Chamber lamp switch	<ul style="list-style-type: none"> • Pos. I: It switches on the light in the oven chamber; • Pos. 0: It switches off the light in the oven chamber.

FIRST COMMISSIONING

Remove the polystyrene underneath the refractory stones and the protective film avoiding using tools that can damage the surfaces.



FOR THE SAFETY REASONS, THE MAXIMUM TEMPERATURE ALLOWED TO BE SET IS 500°C.



THE FIRST COMMISSIONING CAN BE CARRIED OUT ONLY AFTER AN INSTALLATION CARRIED OUT BY AUTHORIZED PERSONEL WHO WILL ISSUE A DECLARATION OF CONFORMITY.

The first commissioning must be carried out as follows:

- 1) Clean the front of the oven with a dry, soft cloth to remove any residue;
- 2) Connect the plug to the socket;
- 3) Push "ON/OFF" button;
- 4) Set the oven temperature to **150°C**
- 5) Let the oven work for about **1 h**.
- 6) Turn the oven off by pressing ON/OFF button;
- 7) Open the door for about **15 min** in order to let eventual vapors and smell go out;
- 8) Close the door and repeat the process described in Section **4)** at the temperature of **300°C**;
- 9) Let the oven work for about **1 h**;
- 10) Switch the heating elements off by putting "ON/OFF" button in off position.

TURNING ON OVEN

- 1) Connect the plug to the socket;
- 2) Push the "ON/OFF" button;
- 3) Set the oven temperature to desired
- 4) Once the oven has reached the desired temperature, it is possible to insert the pizza in the oven for the backing;
- 5) Open the oven manually using the suitable handles;
- 6) To switch the light on, press the oven lamp button;
- 7) Insert the pizza and/or the pizzas to be backed using suitable devices. It is important to avoid leaving the door open for too long, since the temperature drops down.
- 8) Close the door again and check the backing through the glass door;
- 9) The baking temperature varies if it is positioned directly on the refractory stone or on a baking pan. In the first case, it is suggested to set the backing temperature at **280 °C** for the bottom and **320 °C** for the ceiling; in the second case, set **320 °C** for the bottom and **280 °C** for the ceiling;
- 10) When the baking process is over, open the door extract the pizza (or pizzas) and close the door again.

TURNING OFF THE OVEN

Once the use of the oven has ended, proceed as follows:

For turning off the oven press the ON/OFF button.

MAINTENANCE



BEFORE PERFORMING ANY TYPE OF MAINTENANCE INTERVENTION, IT IS COMPULSORY TO DISCONNECT THE PLUG OF THE OVEN FROM THE POWER SUPPLY OUTLET.

CLEANING

The clearing must be done every time the oven has been used following all the rules to prevent malfunctioning of the oven and for hygienic purpose.

Cleaning of the refractory surface: this operation has to be performed with hot oven. Once the **temperature of about 350°C has been reached**, turn off the oven, open the door and clean the surface using a **brush in vegetable fiber equipped with a long handle in order to avoid the contact with the oven hot parts.**

External clearing of the oven: (surfaces in stainless steel, inspection WIDE and control panel): this operation has to be performed with cold oven.



IT IS RECOMMENDED TO THE OPERATOR IN CHARGE TO USE PROPER GLOVES AND SUITABLE CLOTHING TO AVOID BURNINGS.



IT IS FORBIDDEN TO USE THROWS OR DRIPS OF WATER, ABRASIVE OR CORROSIVE SUBSTANCES, AND ANYTHING ELSE THAT CAN DAMAGE THE COMPONENTS, COMPROMISE THE SAFETY, AND BE DANGEROUS FROM AN HYGIENIC POINT OF VIEW.

For any intervention of supplementary maintenance, repairing and/or replacement refer exclusively to the authorized dealer where the oven has been purchased and/or to an authorized technician satisfying the technical and professional requirements stated by the regulations in force.

DEMOLITION

GENERAL WARNINGS

When dismantling the oven, compulsorily observe the provisions of the regulations in force. Differentiate the parts making up the oven according to different types of construction materials (plastic, copper, iron, etc.).

SPARE PARTS

ONE CHAMBER OVEN EXLODED VIEW

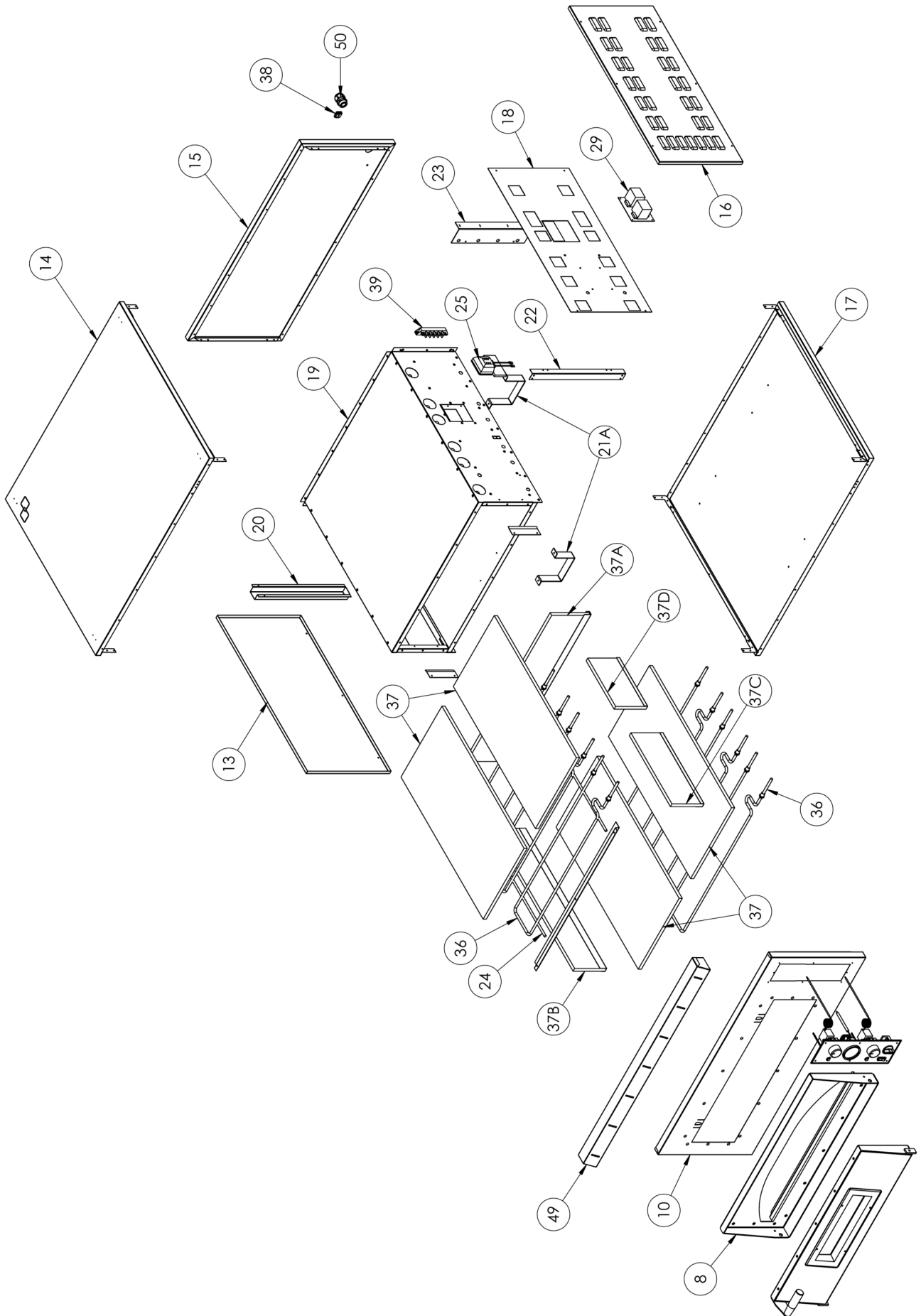

TWO CHAMBER OVEN EXLODED VIEW

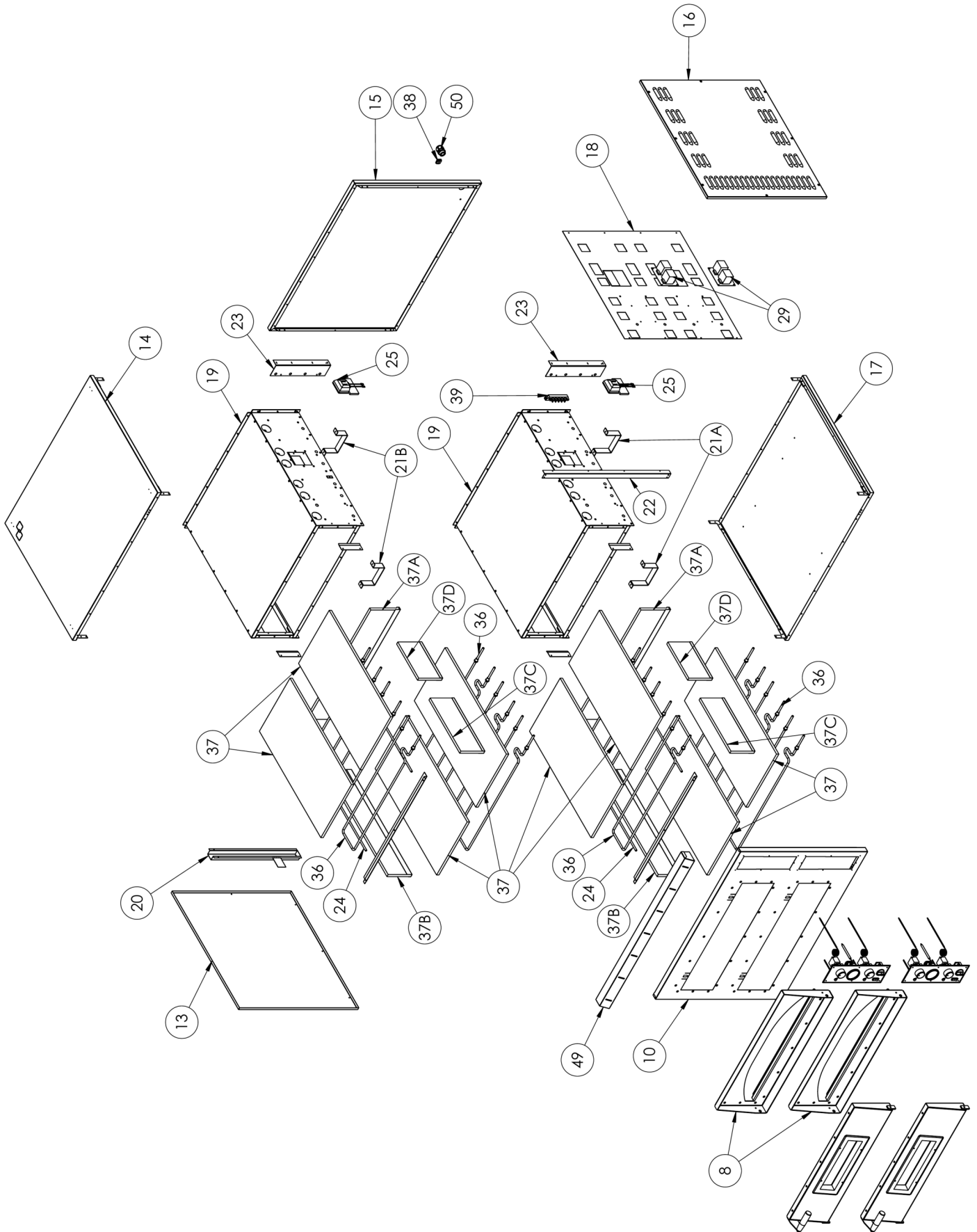

DOOR EXPLODED VIEW

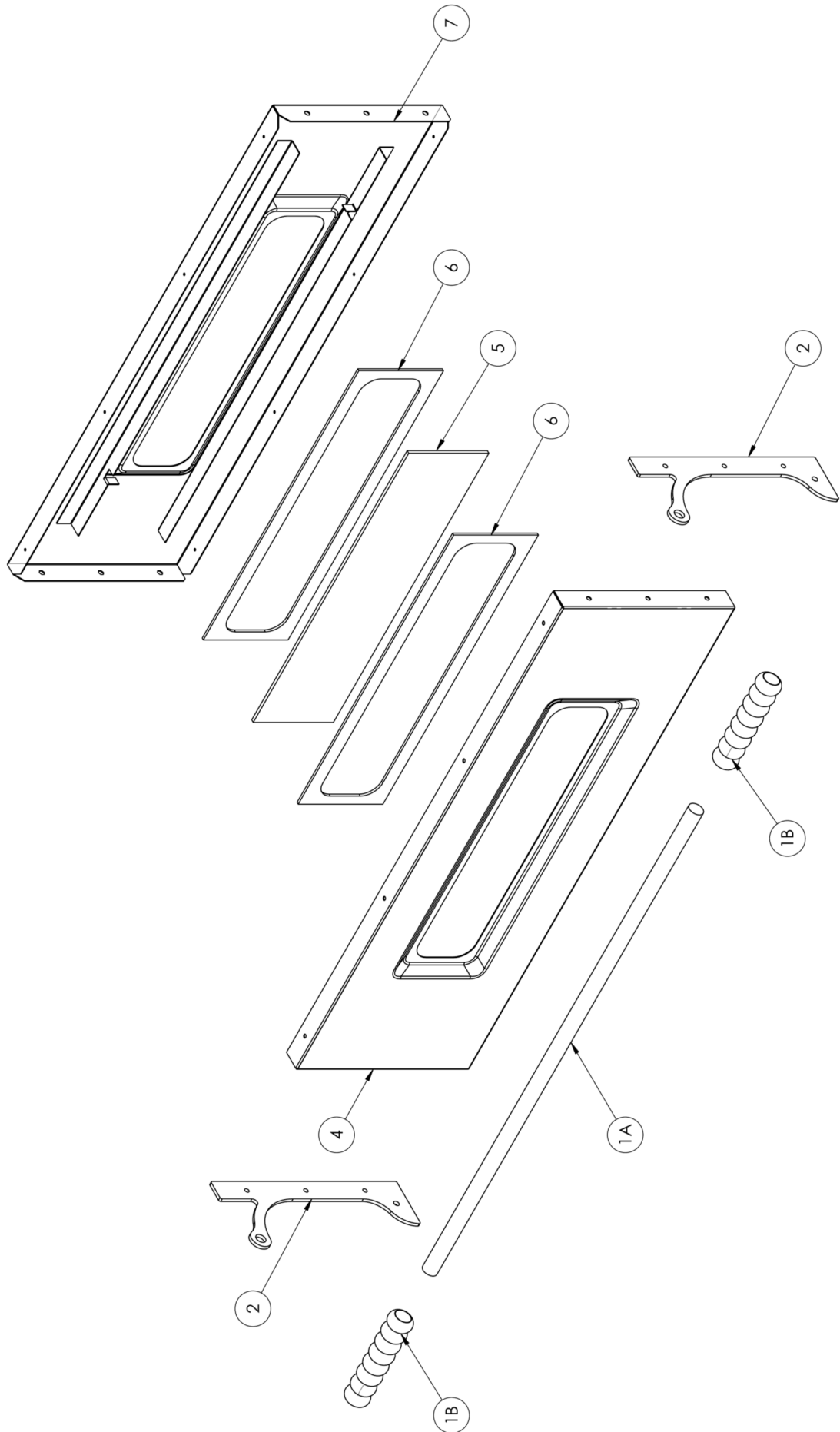

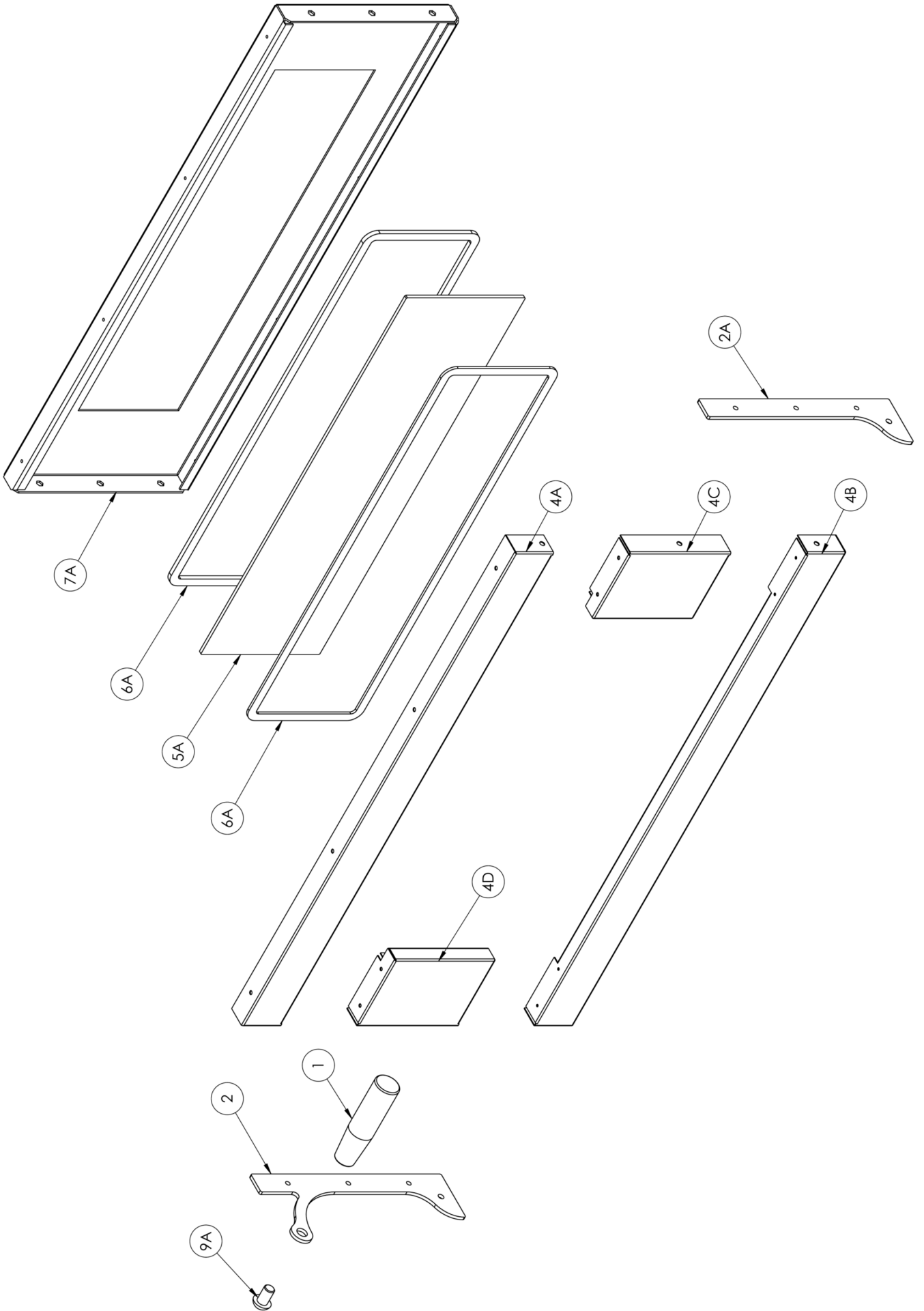

CONTROL UNIT EXPLODED VIEW

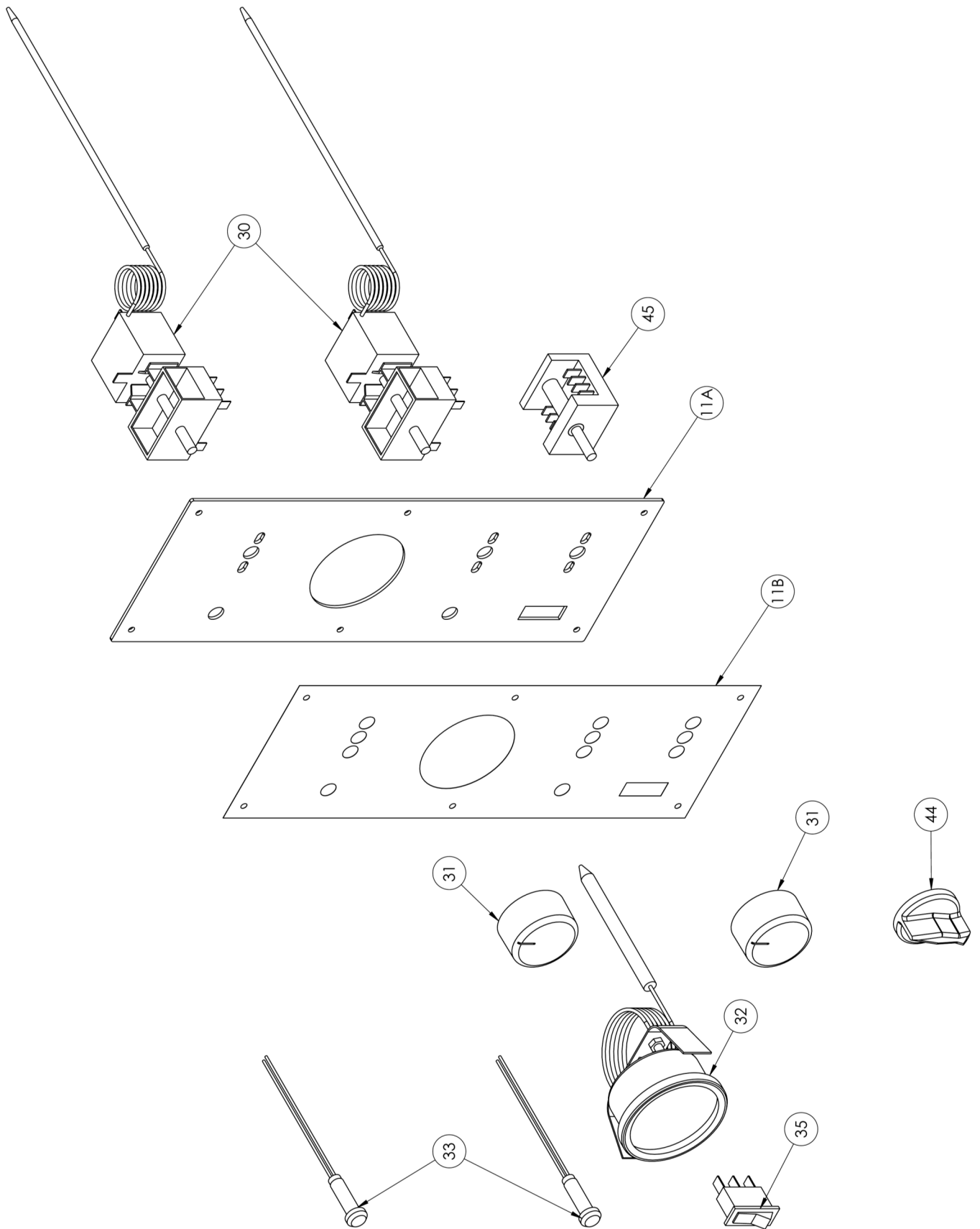

SPARE PARTS

	MILAN 1	MILAN 2	ROME 1	ROME 2	NAPELS 1	NAPELS 2
1	5M200030	5M200030	5M200030	5M200030	5M200030	5M200030
1A	7M010007	7M010007	7M010005	7M010005	7M010007	7M010007
1B	5M200016	5M200016	5M200016	5M200016	5M200016	5M200016
2	4P100007	4P100007	4P100007	4P100007	4P100007	4P100007
2A	-	-	-	-	-	-
3	3R030001	3R030001	3R030001	3R030001	3R030001	3R030001
4	4P050018	4P050018	4P050017	4P050017	4P050018	4P050018
4A	4P050012	4P050012	4P050010	4P050010	4P050012	4P050012
4B	4P050013	4P050013	4P050011	4P050011	4P050013	4P050013
4C	4P050078	4P050078	4P050078	4P050078	4P050078	4P050078
4D	4P050079	4P050079	4P050079	4P050079	4P050079	4P050079
5	5V010015	5V010015	5V010015	5V010015	5V010015	5V010015
5A	5V010023	5V010023	5V010022	5V010022	5V010022	5V010023
6	5G100001	5G100001	5G100001	5G100001	5G100001	5G100001
6A	5G100018	5G100018	5G100018	5G100018	5G100018	5G100018
7	4C020028	4C020028	4C020027	4C020027	4C020028	4C020028
7A	4C020010	4C020010	4C020030	4C020030	4C020010	4C020010
9	5V500120	5V500120	5V500120	5V500120	5V500120	5V500120
9A	5V500046	5V500046	5V500046	5V500046	5V500046	5V500046
11A	4M020031	4M020031	4M020031	4M020031	4M020031	4M020031
24	4T060080	4T060080	4T060065	4T060065	4T060000	4T060000
25	7P010200	7P010200	7P010200	7P010200	7P010200	7P010200
26	5V010003	5V010003	5V010003	5V010003	5V010003	5V010003
27	5L020005	5L020005	5L020005	5L020005	5L020005	5L020005
29	-	-	-	-	5S010050	5S010050
30	5T010001	5T010001	5T010001	5T010001	5T010001	5T010001
31	5M200003	5M200003	5M200003	5M200003	5M200003	5M200003
32	5T010200	5T010200	5T010200	5T010200	5T010200	5T010200
33	5L020017	5L020017	5L020017	5L020017	5L020017	5L020017
35	5I100017	5I100017	5I100017	5I100017	5I100017	5I100017
36	5R050420	5R050420	5R050400	5R050400	5R050415	5R050415
37	5P050135	5P050135	5P050040	5P050040	5P050040	5P050040
37A1	-	-	5P050090	5P050090	5P050090	5P050090
37A2	-	-	-	-	5P050092	5P050092
37B	-	-	5P050086	5P050086	5P050086	5P050086
37C	-	-	5P050084	5P050084	5P050084	5P050084
37D	-	-	5P050080	5P050080	5P050080	5P050080
38	5M100120	5M100120	5M100120	5M100120	5M100120	5M100120
39	5M100010	5M100010	5M100010	5M100010	5M100010	5M100010
44	5M200013	5M200013	5M200013	5M200013	5M200013	5M200013
45	5I100023	5I100023	5I100023	5I100023	5I100023	5I100023
50	5P100003	5P100003	5P100003	5P100003	5P100003	5P100003

ELECTRIC EQUIPMENT

LIST OF COMPONENTS

MARK	DESCRIPTION
T	Single (1) pole thermostat
TT	Three (3) poles thermostat
QS0	Heating elements on/off switch
HL	Heating elements spy light
QF0/1	Chamber light on/off switch
K	Contactor
TI	Timer

WIRING DIAGRAMS

**MILAN
ROME**

**400V/3PH
(one chamber)**

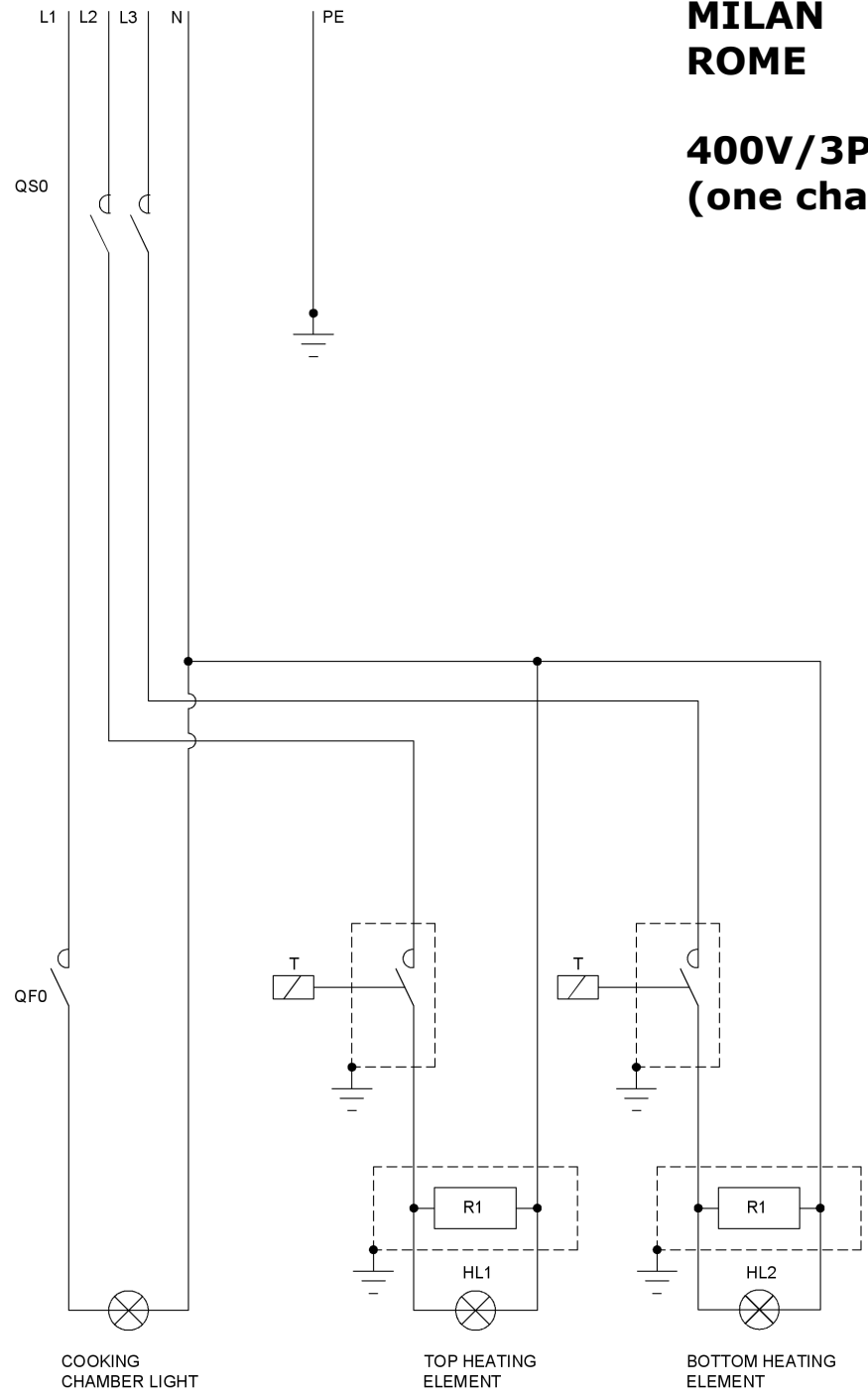

Legend of oven wiring diagrams

T unipolar thermostat;
 QS0 heating element power switch;
 HL heating elements spy light;
 QF0 chamber light on/off switch;

MILAN ROME

230V/1PH (one chamber)

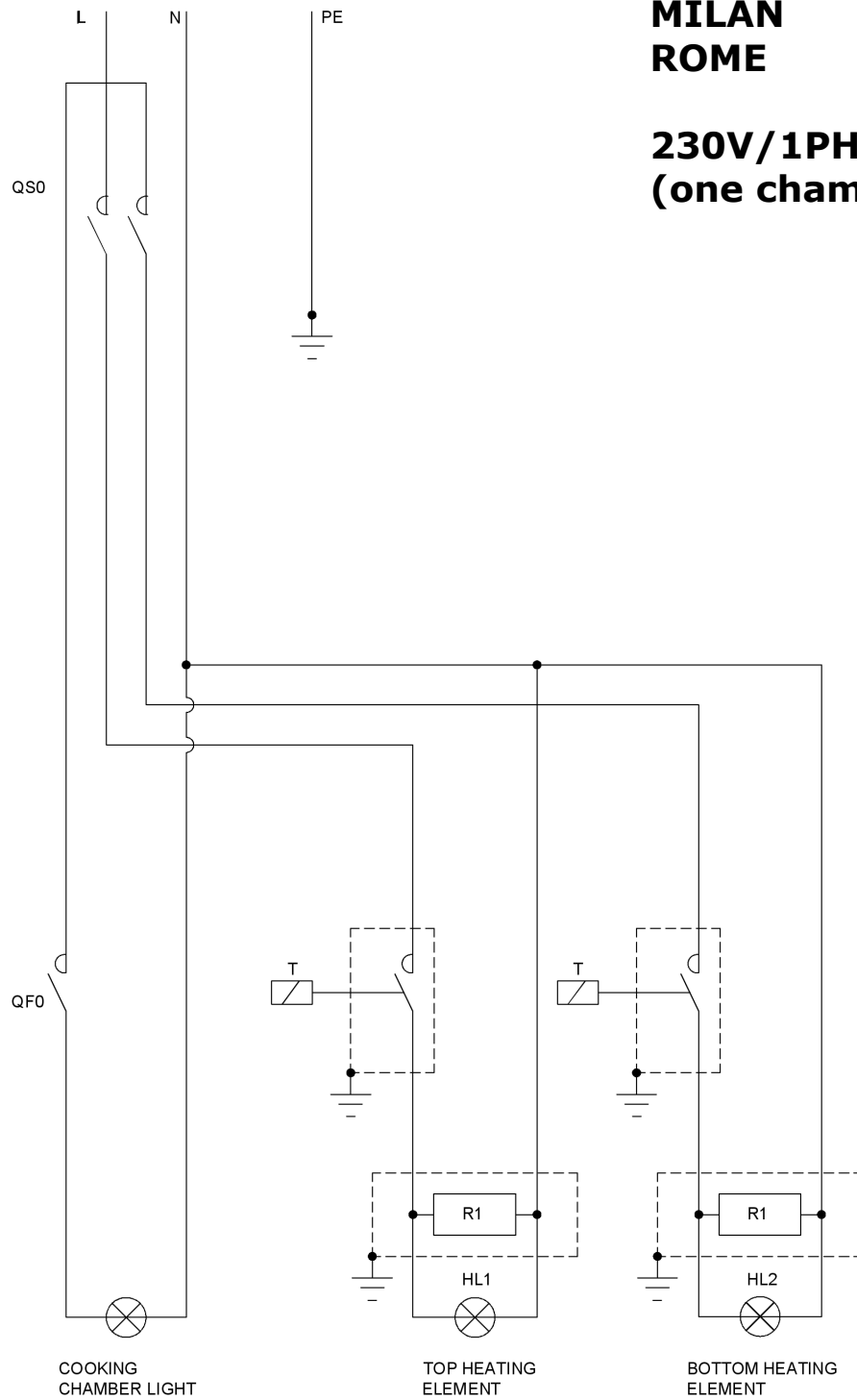

Legend of oven wiring diagrams

T	unipolar thermostat;
QS0	heating element power switch;
HL	heating elements spy light;
QF0	chamber light on/off switch;

MILAN ROME

**230V/3PH
(one chamber)**

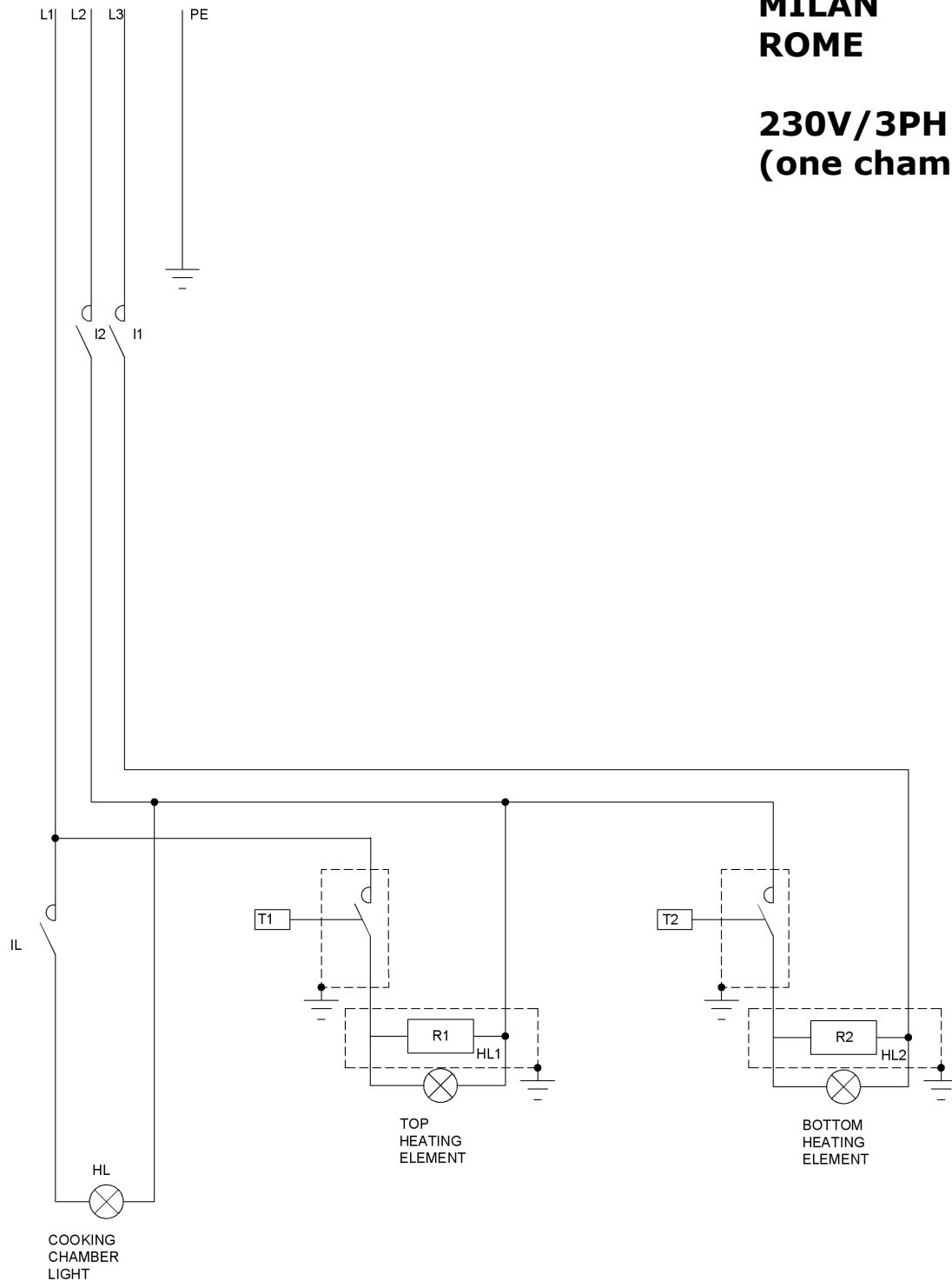

Legend of oven wiring diagrams

- T unipolar thermostat;
- I heating element power switch;
- HL inside lamp pilot light;
- IL switch for the inside lamp

NAPELS

**400V/3PH
(one chamber)**

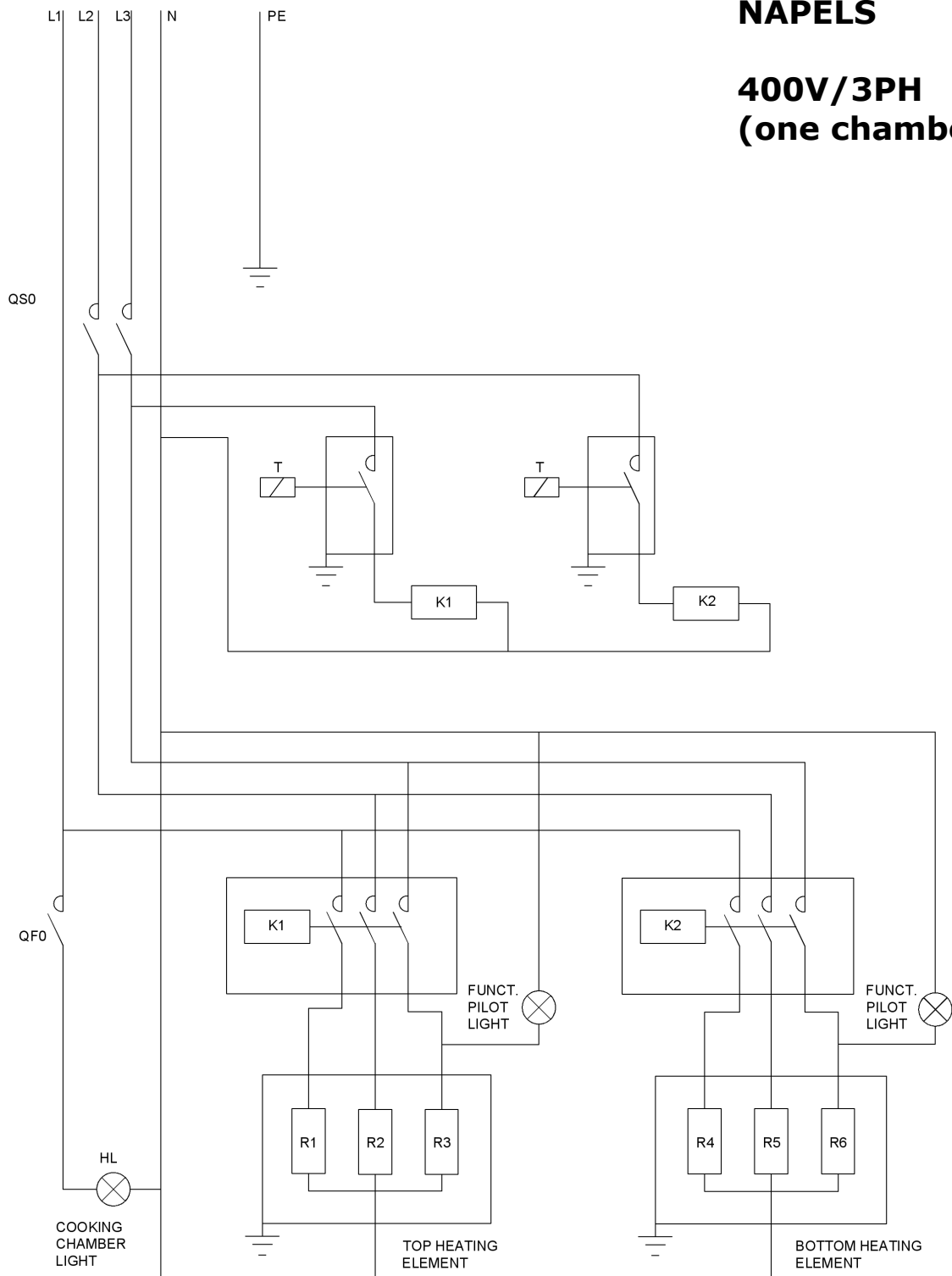

Legend of oven wiring diagrams

- T unipolar thermostat;
- K contactor;
- QS0 heating element power switch;
- HL inside lamp pilot light;
- QF0 switch for the inside lamp

NAPELS

230V/1PH
(one chamber)

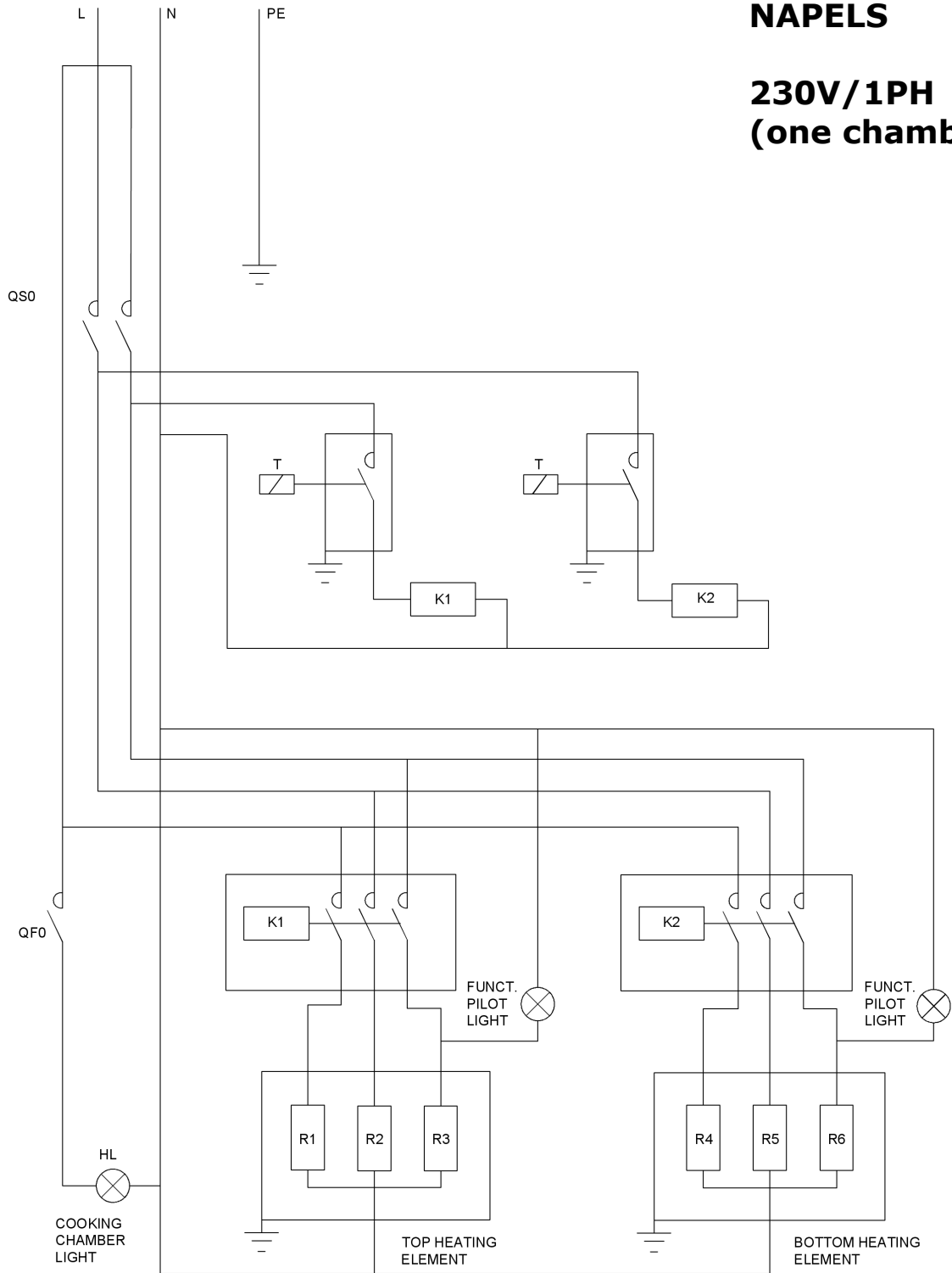

Legend of oven wiring diagrams

- T unipolar thermostat;
- K contactor;
- QS0 heating element power switch;
- HL inside lamp pilot light;
- QF0 switch for the inside lamp

NAPELS

**230V/3PH
(one chamber)**

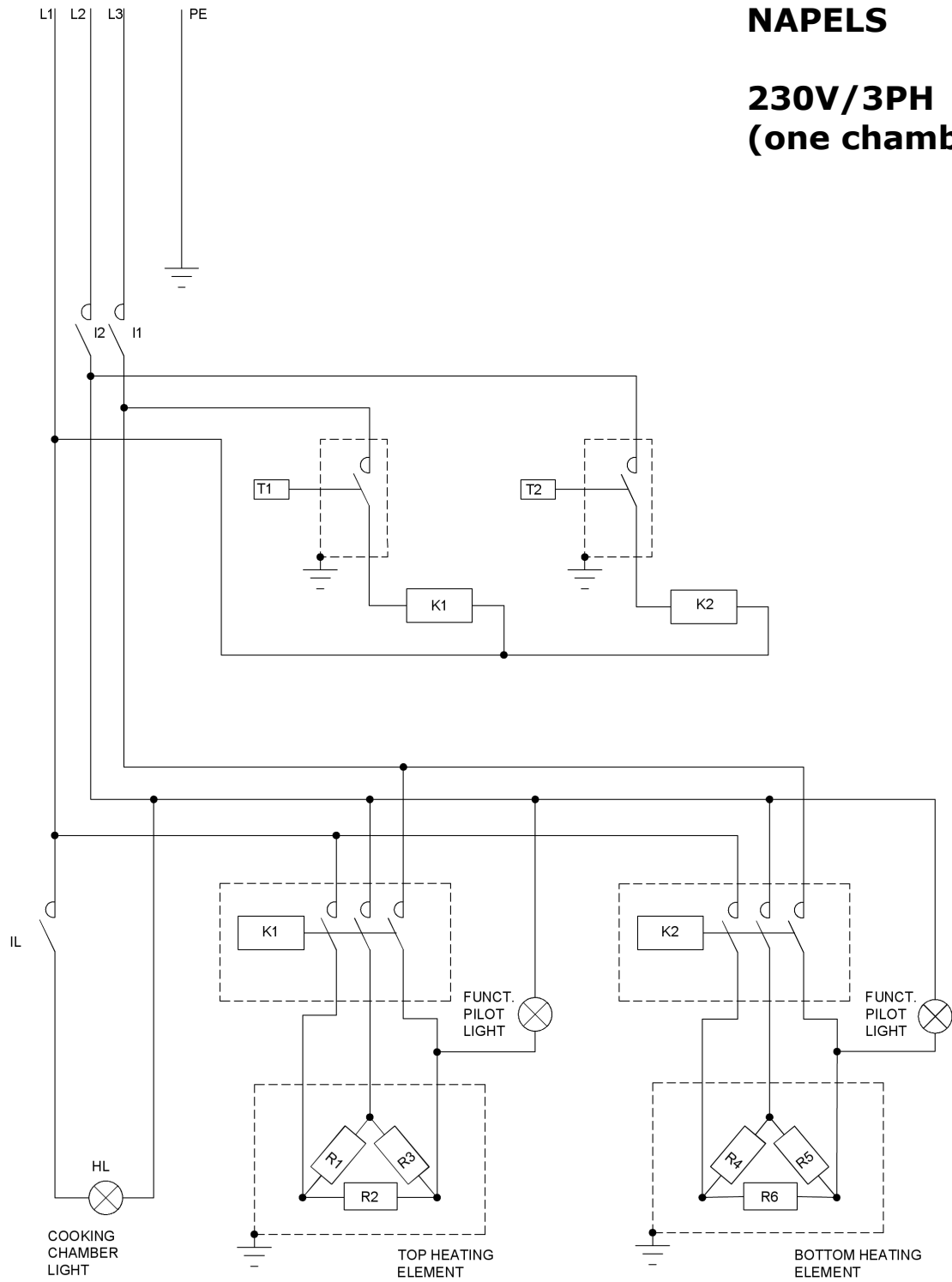

Legend of oven wiring diagrams

- T unipolar thermostat;
- K contactor;
- I heating element power switch;
- HL inside lamp pilot light;
- IL switch for the inside lamp

